

# *AirEZ*

## Executive Summary

American Helicopter Society International  
32<sup>nd</sup> Annual Student Design Competition  
Graduate Student Team Submission

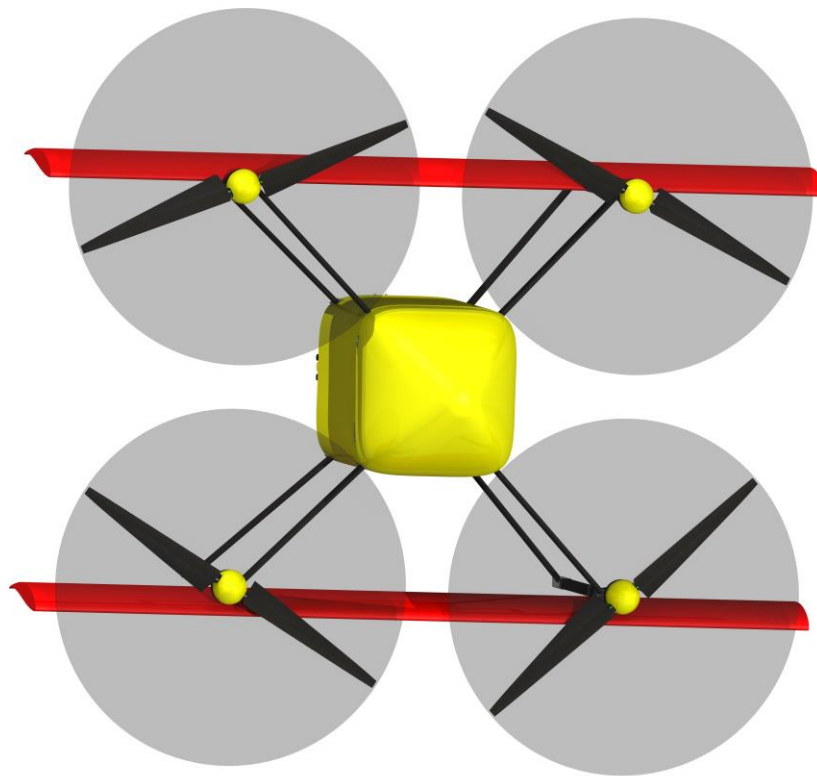

UNIVERSITY OF  
MARYLAND

# Overview: AirEZ Vehicle

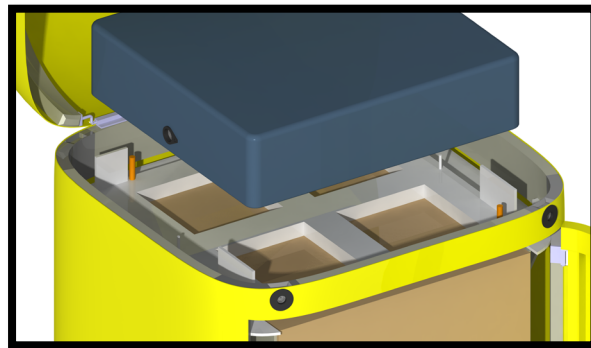

## Battery

- 2.04 kW-hr lithium-sulfur battery
- Quick swappable for turn around time

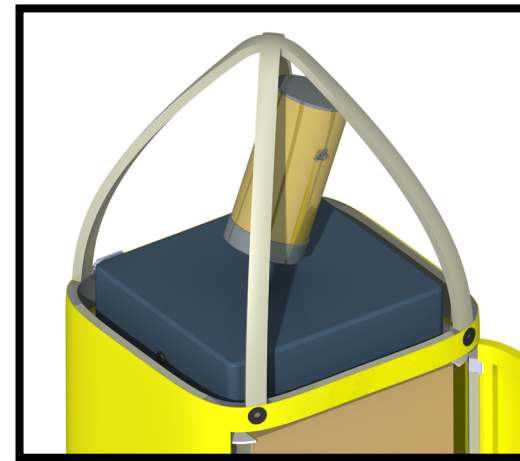

## Emergency Parachute

- Angled to work in hover and cruise
- Tangle-proof

## Quadrotor Tailsitter Biplane

- High endurance, high speed, long range, and VTOL capable

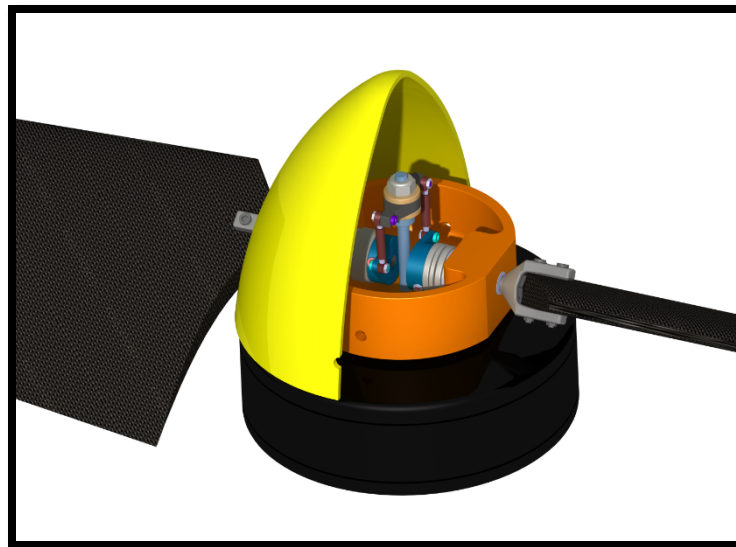
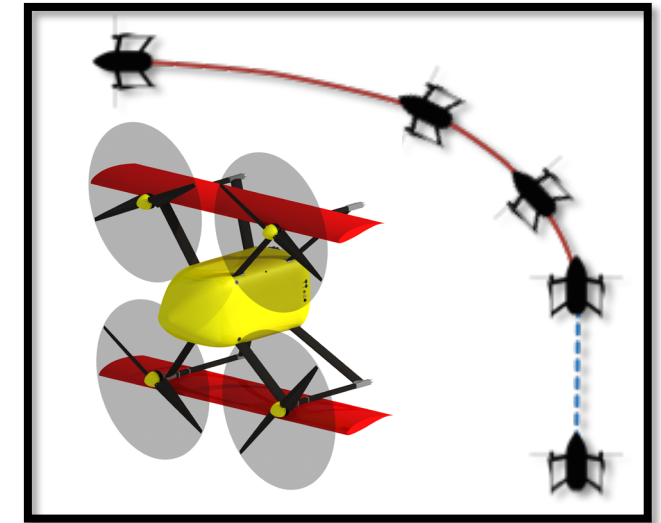

## Proprotors

- Low maintenance rigid hub
- Variable collective for max efficiency
- Variable RPM for high controllability
- Optimized composite blades

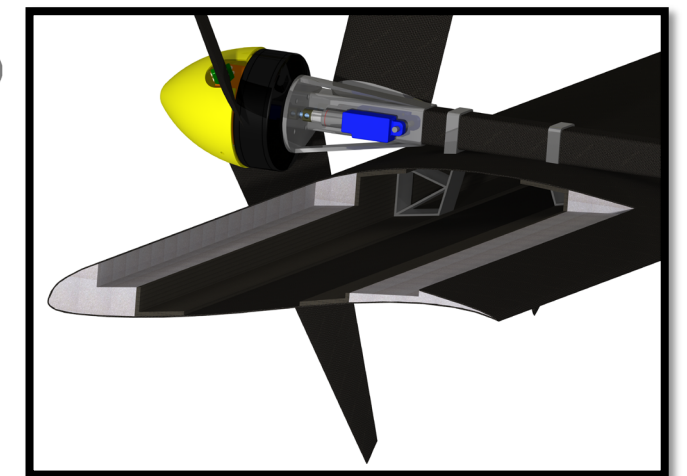
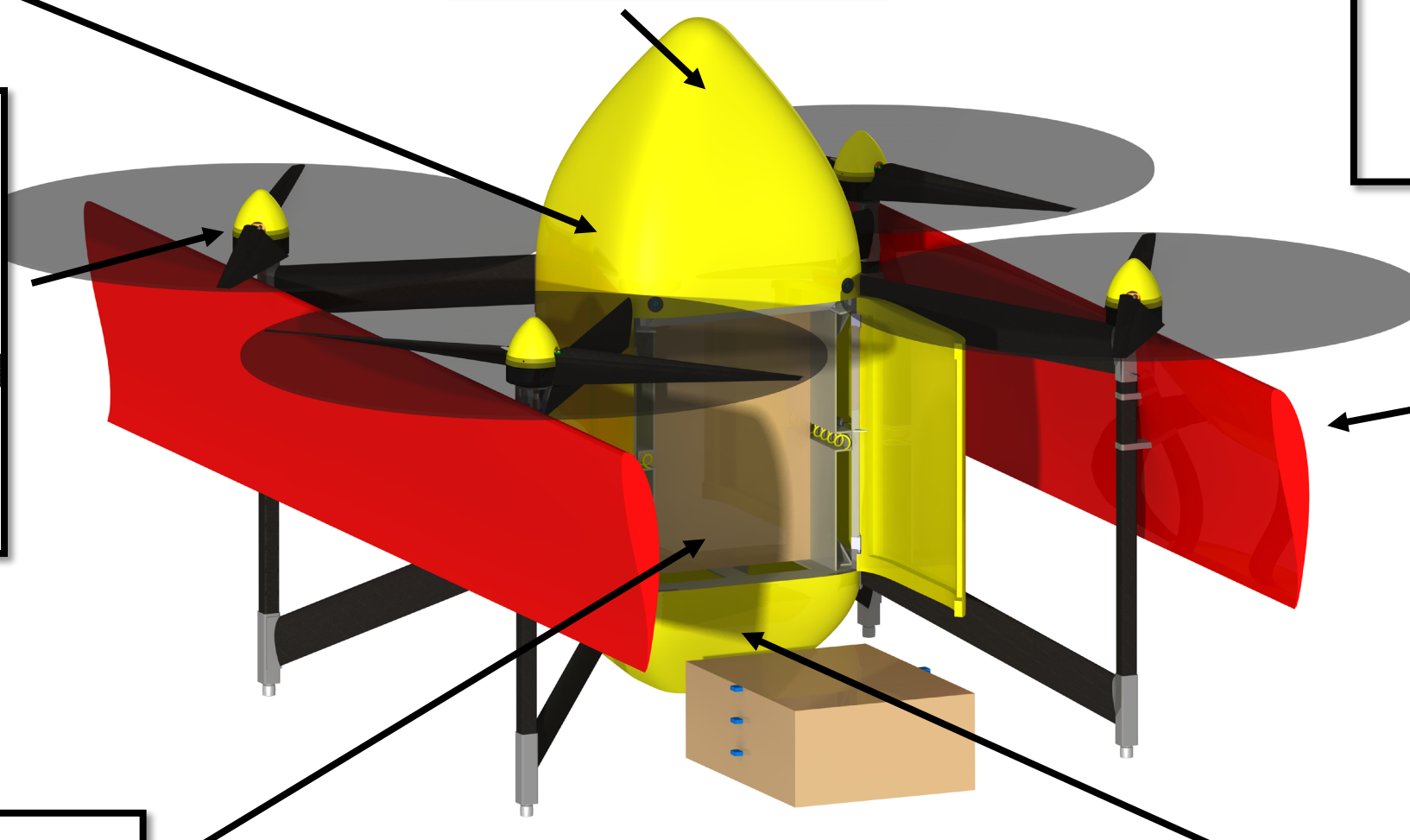

## Wing

- Lightweight composite construction
- Modularized to be easily replaceable

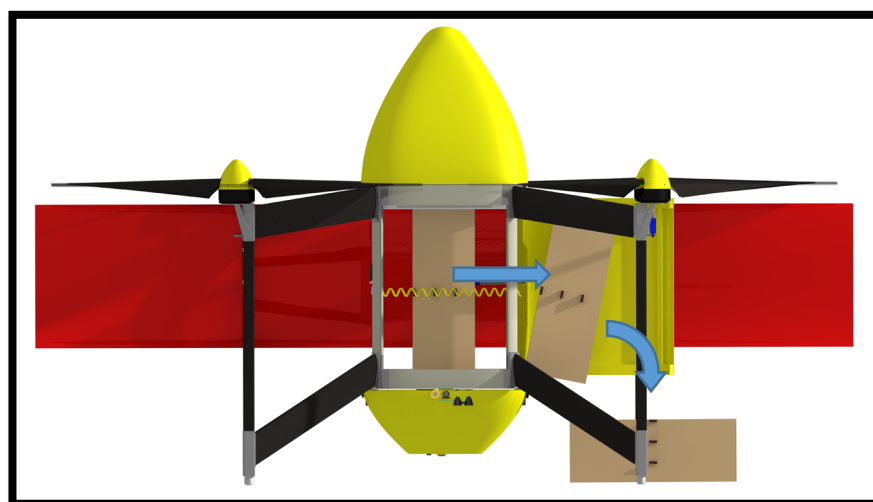

## Delivery System

- Deliver multiple packages per trip
- Minimal actuators for low maintenance
- Auger based package deployment

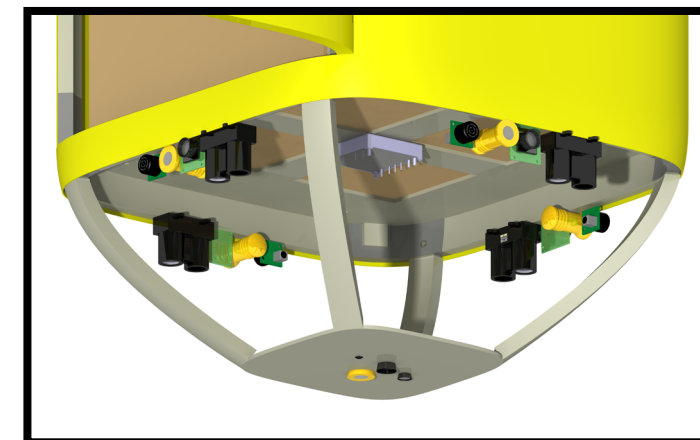

## Electronics Suite

- Robust sense-and-avoid sensor suite
- Redundant communications systems
- HEMS early warning system

# THE *AirEZ* SYSTEM INTRODUCTION

In response to the AHS Student Design Competition 2015 Request for Proposal for a complete aerial delivery system of systems, the University of Maryland graduate team presents *AirEZ*, a fully developed logistics system that can be implemented using available state-of-the-art technology.

The *AirEZ* vehicle is a novel quadrotor-biplane-tailsitter concept with the ability to hover, transition quickly into high speed forward flight, and efficiently transition back to hover for landing. These capabilities have all been demonstrated at a smaller scale at the University of Maryland. The vehicle's simple structural design enables inexpensive mass manufacturing, leading to a delivery system that can provide 2-hour delivery within a 50 mi x 50 mi region at a cost of only \$9.03 per package.

The *AirEZ* vehicle is outfitted with an advanced sensor package enabling autonomous navigation in the crowded airspace of an urban environment. Package delivery is performed safely and reliably with minimal expense to the logistics company. To demonstrate the viability of this innovative concept, a scaled model was built and successfully tested in different flight modes.

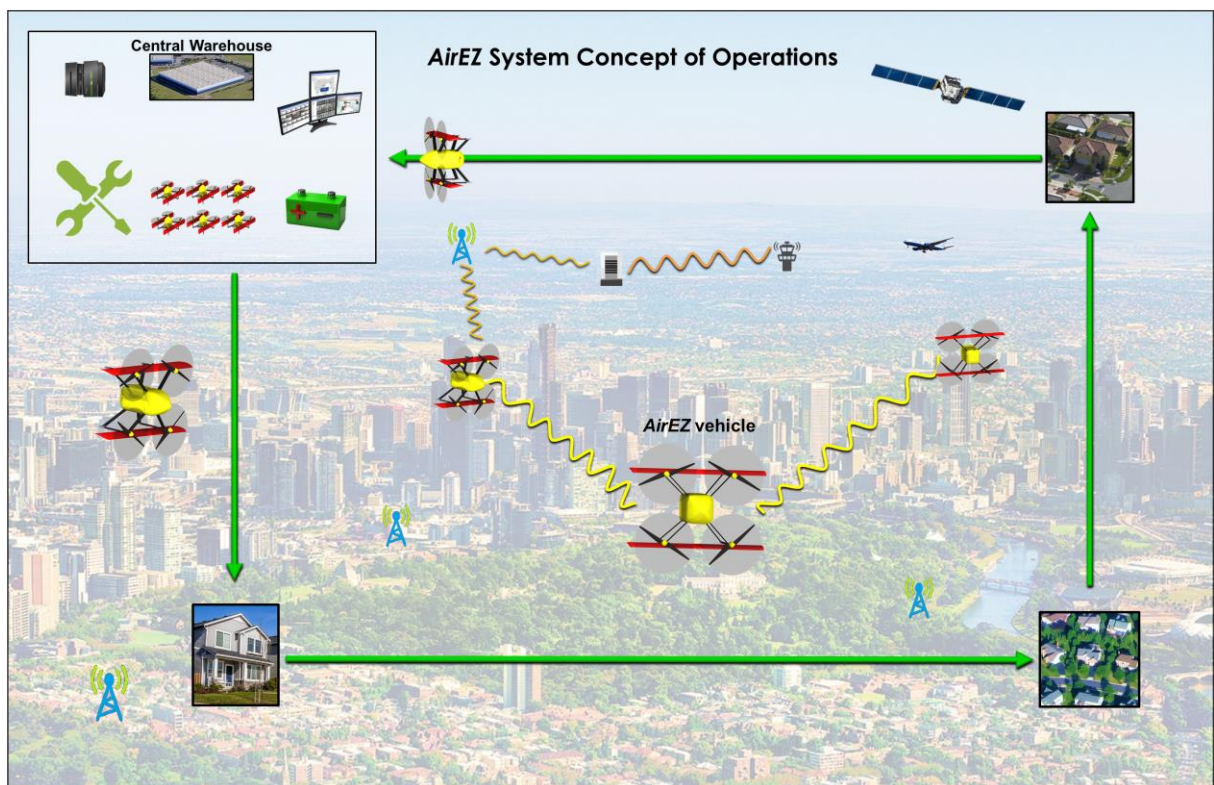

# MISSION AND MEASURES OF EFFECTIVENESS

The AirEZ system shows impressive performance in each of the five Measures of Effectiveness (MoE).

## MoE 1: System Acquisition and Yearly Operating Cost

	Cost (Millions)
Development	\$4.13
<b>Acquisition</b>	<b>\$6.77</b>
Direct Operating (3 yrs)	\$15.83
Indirect Operating (3 yrs)	\$6.33
End of Life	\$1.0
<b>Yearly Operating</b>	<b>\$7.39</b>

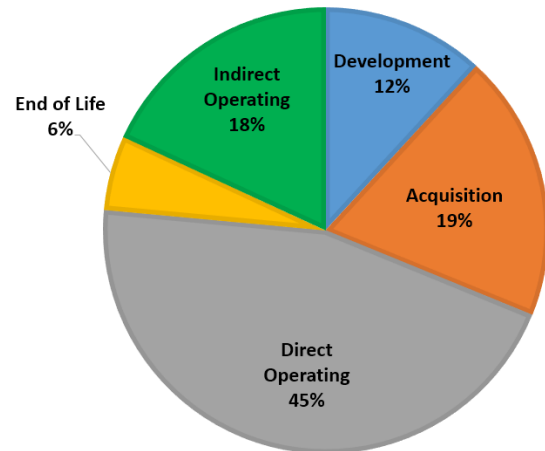

## MoE 2: Packages Delivered Per Vehicle Per Day

The AirEZ system has been designed using vehicles which carry multiple packages per trip. Utilizing this capability has led to a system in which each vehicle delivers an average of 11 packages per day at a cost of \$9.03 per package. Vehicles that can carry only one package per trip reduce the system productivity to 8 packages per vehicle per day (27% worse).

## MoE 3: Number of Deliveries Requiring More Than 90 Minutes

0 packages weighing less than 5 lb and smaller than 12x12x16 in require more than 90 minutes to deliver.

## MoE 4: Pounds of CO<sub>2</sub> per Delivery Mile Flown

AirEZ produces **0.067 lb** of CO<sub>2</sub> per delivery mile flown. This number is based on the CO<sub>2</sub> emissions for grid-based charging specified in the RFP. When compared to light-duty trucks with CO<sub>2</sub> emissions of 0.814 lb/mi or hybrid cars with 0.331 lb/mi, AirEZ is 92% and 80% better respectively. The choice of batteries as the power plant ensures that AirEZ is an **environmentally green reality**.

## MoE 5: Mission Success Rate

Based on detailed simulations, AirEZ boasts an overall mission success rate of **86%**, similar to any major carrier's success rate for express over-night deliveries.

# SYSTEM CAPABILITIES

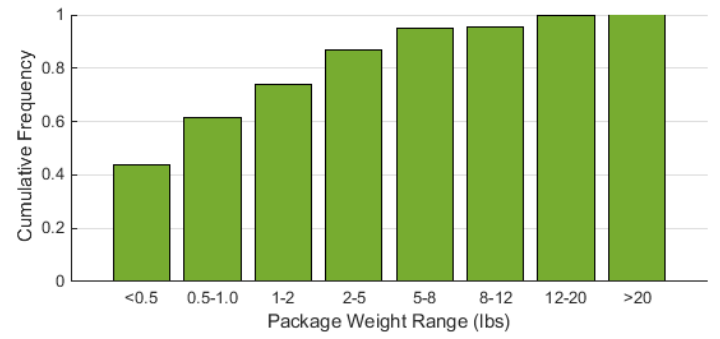
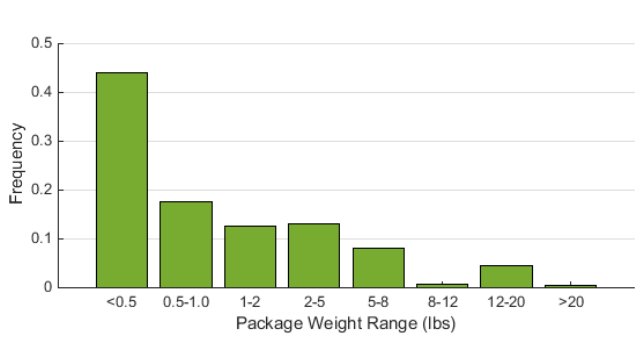

Vehicle Fleet	
# active vehicles	<b>400</b>
# standby vehicles	<b>80</b>
Personnel	
Central Command	<b>5</b>
Maintenance	<b>10</b>

## Delivery radius of action for given payload

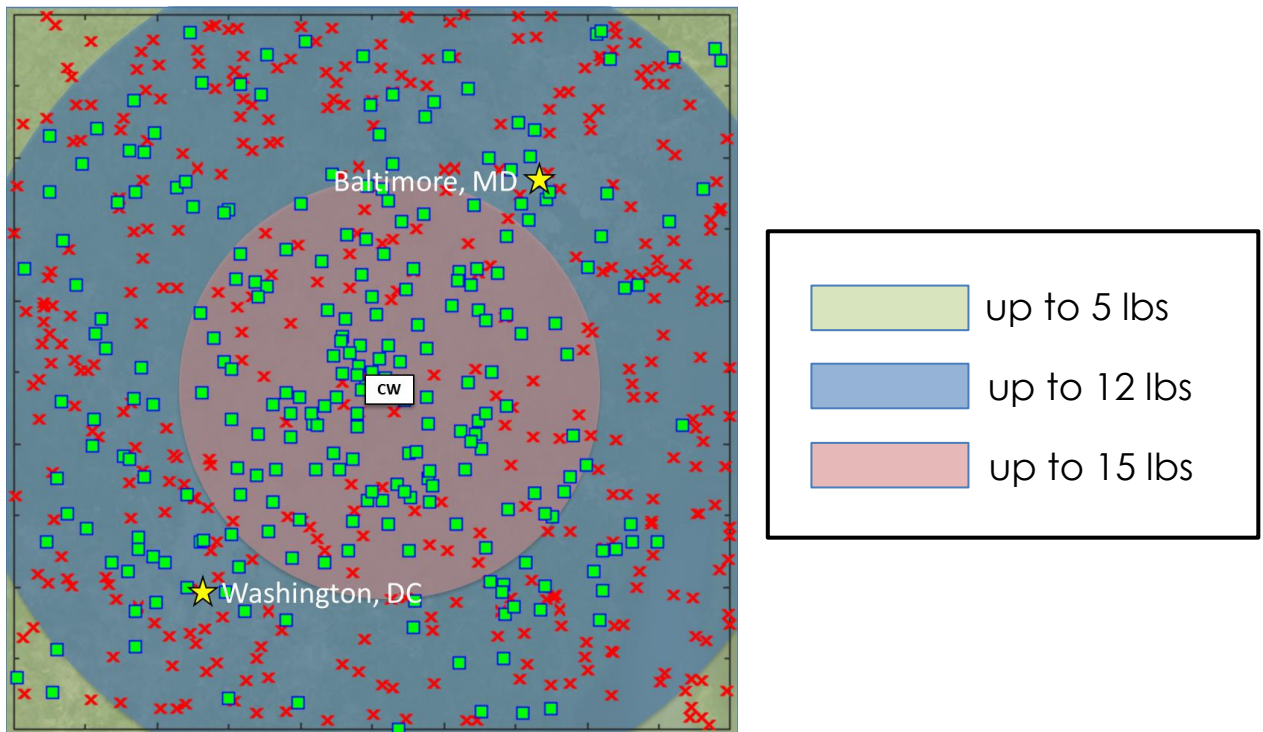

# COMPLETE MISSION SIMULATION

The mission outlined by the RFP is for daily delivery of 5,000 packages across a 50 mi x 50 mi region. The packages are of varying weights, and must be delivered within two hours of being requested. A robust in-house simulation environment was developed by the University of Maryland team to model a typical delivery day and explore the options for system configuration and vehicle capabilities.

Simulations were carried out:

- Vehicle routing strategies for delivering multiple packages per trip
- Use of forward supply locations as waypoints or charging stations
- Shuttle vehicles to move packages to forward locations
- Multiple vehicle designs for differing:
  - Range
  - Package capacity
  - Payload capability

Results from the simulations dictated several key design drivers:

- Multiple packages per trip – reduces number of vehicles by 35% compared to single package per trip
- High speed – ensure packages are delivered within 2 hours, fewer vehicles required, lower maintenance cost
- No forward supply locations – eliminate 50% additional operating costs, for marginal increase in overall energy consumption and acquisition costs

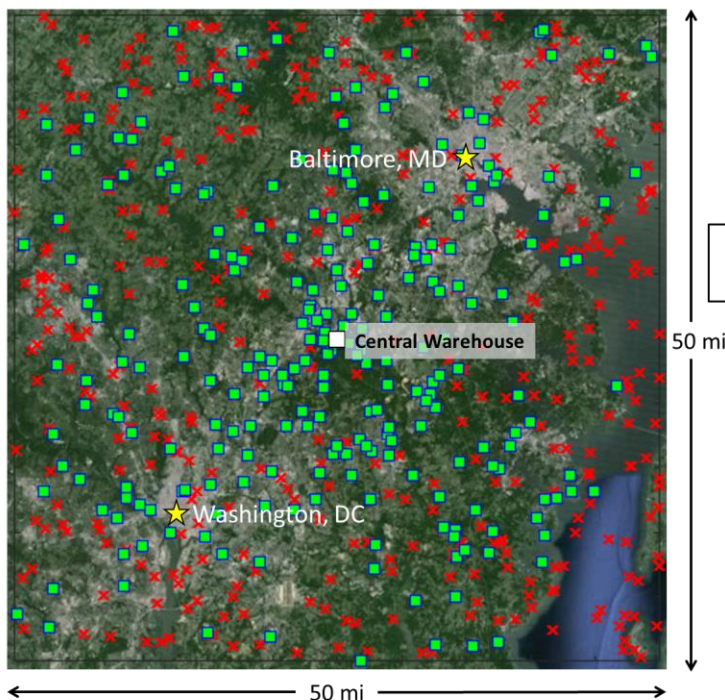

× Package Requests  
■ Delivery Vehicles

Snapshot of a simulation at one instant in delivery day

**300** vehicles in air  
**443** package requests

# Package Delivery Simulation

## Multiple Package Delivery

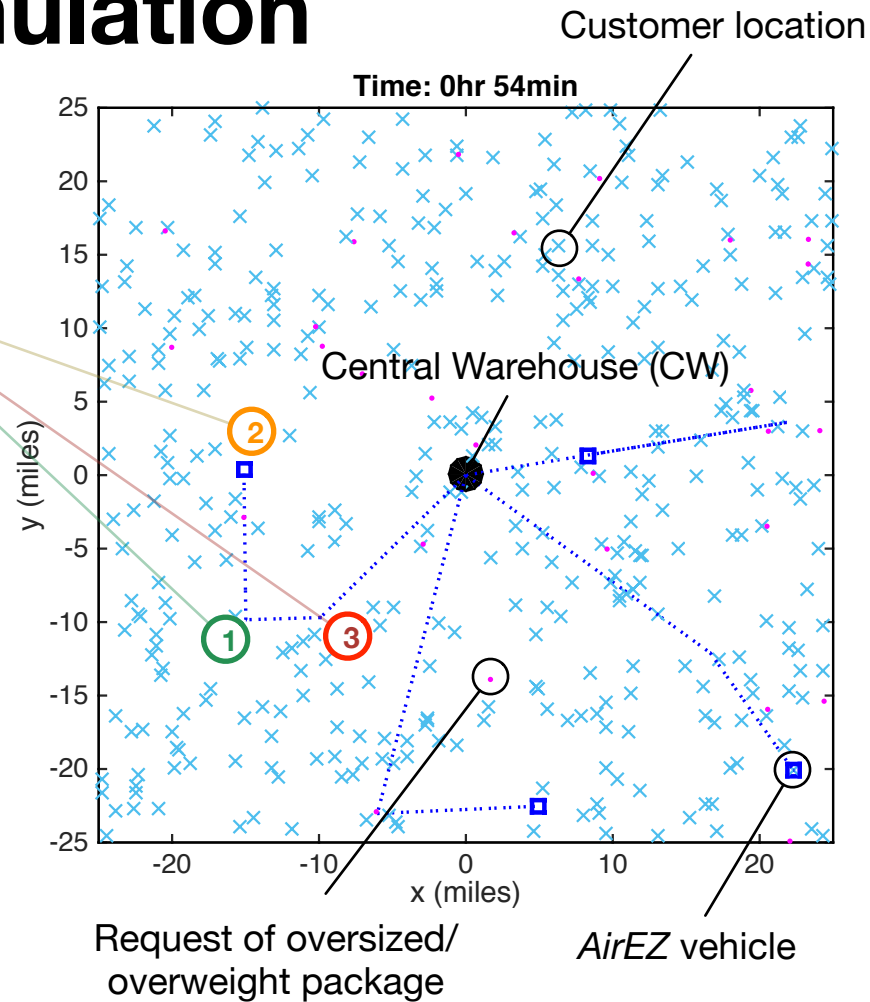
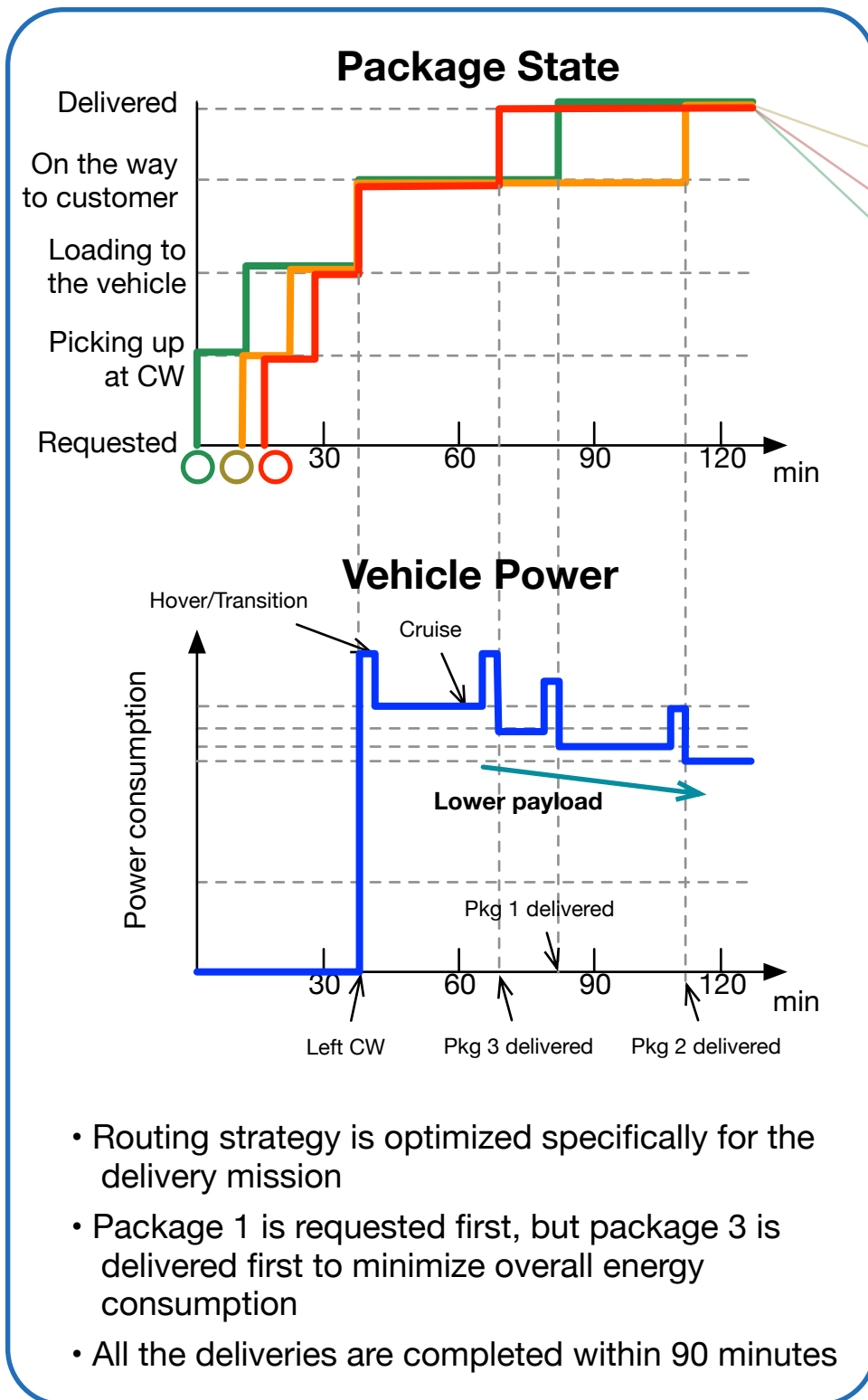

## Concept of Operation

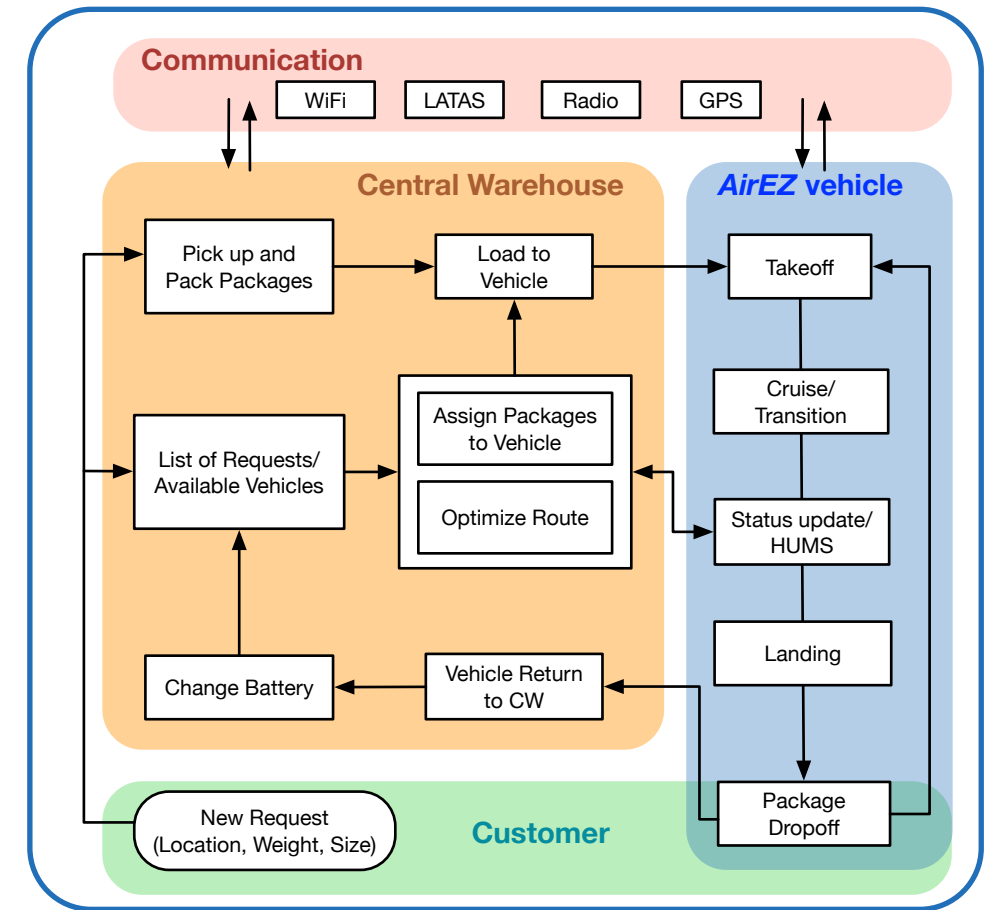

## Typical Delivery Day

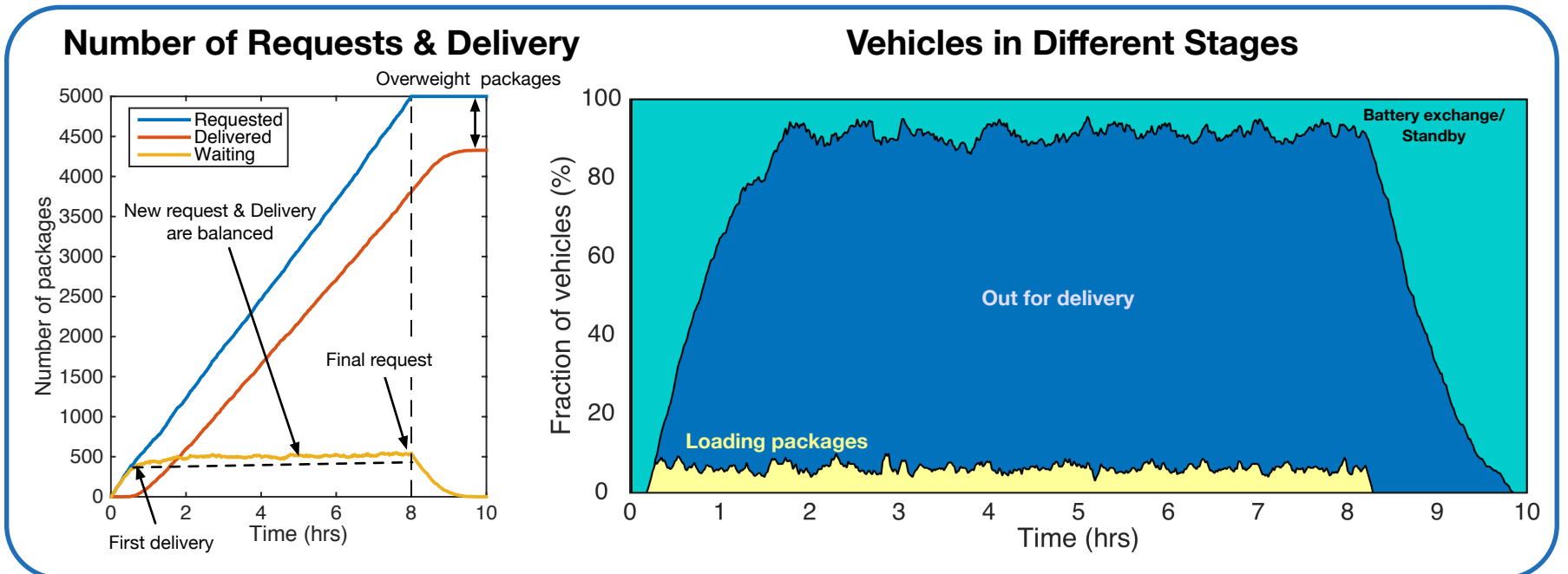

# NOVEL VEHICLE CONFIGURATION

The AirEZ delivery system features a unique quadrotor-biplane-tailsitter configuration demonstrated at the University of Maryland. This design was chosen based on its ability to combine the best aspects of each configuration to meet the goals of the RFP.

## Quadrotor

Quadrotor configuration enables efficient hovering flight and **exceptional controllability**. The unique control options allow for **simple hubs with no swashplates** and **no additional control surfaces** to reduce maintenance costs. In addition, **ground safety** and **operational safety** are enhanced due to lower kinetic energy of its smaller rotors, and redundant rotor system.

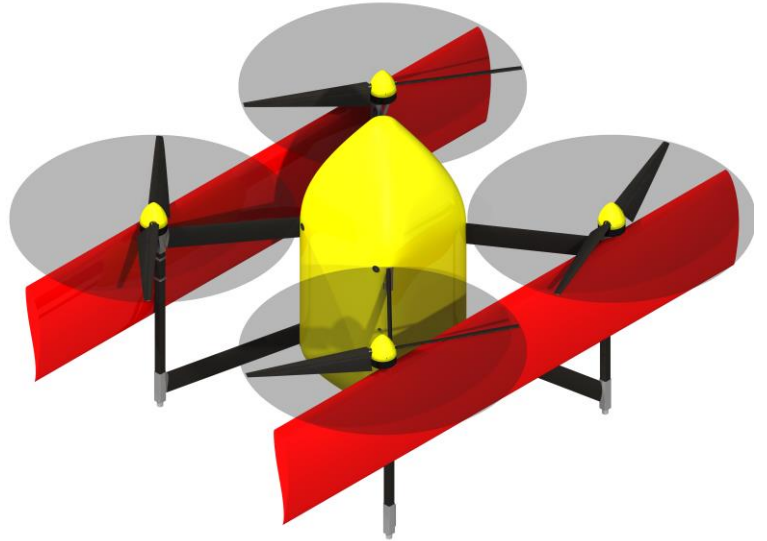

## Tailsitter

Achieving the transition from helicopter to airplane mode via a tailsitter configuration rather than a tilt-rotor allows *AirEZ* to keep a **simple, lightweight design**. The lack of a complicated and heavy mechanism for tilting rotors or wings ensures that the many hundreds of *AirEZ* vehicles in the system are **easy to maintain**.

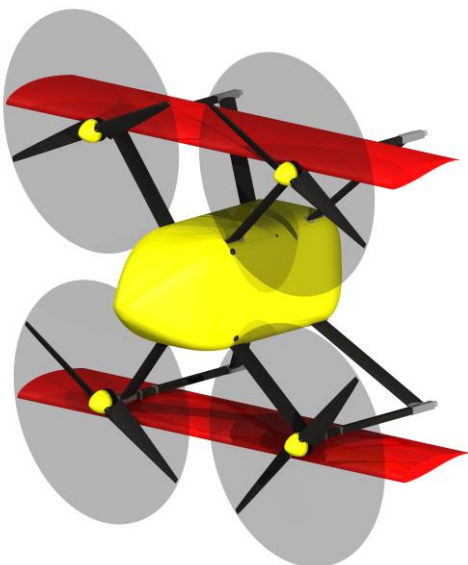

## Biplane

Wings allows *AirEZ* to achieve the **high speed** and **long range** necessary for 2-hour delivery to all points in the service region. The biplane configuration provides the necessary lift in a small footprint. In addition, the wings offload the rotors in forward flight, enabling the rotors to be highly efficient propellers.



# OPTIMIZED PROPOTOR

The *AirEZ* vehicle proprotor offers excellent efficiency as a rotor (FM = 0.73) in hover and as a propeller ( $\eta = 0.85$ ) in forward flight through the use of variable RPM and adjustable root pitch control. Optimization was achieved through parametric studies on:

- Number of blades
- Chord
- Taper ratio
- Twist rate

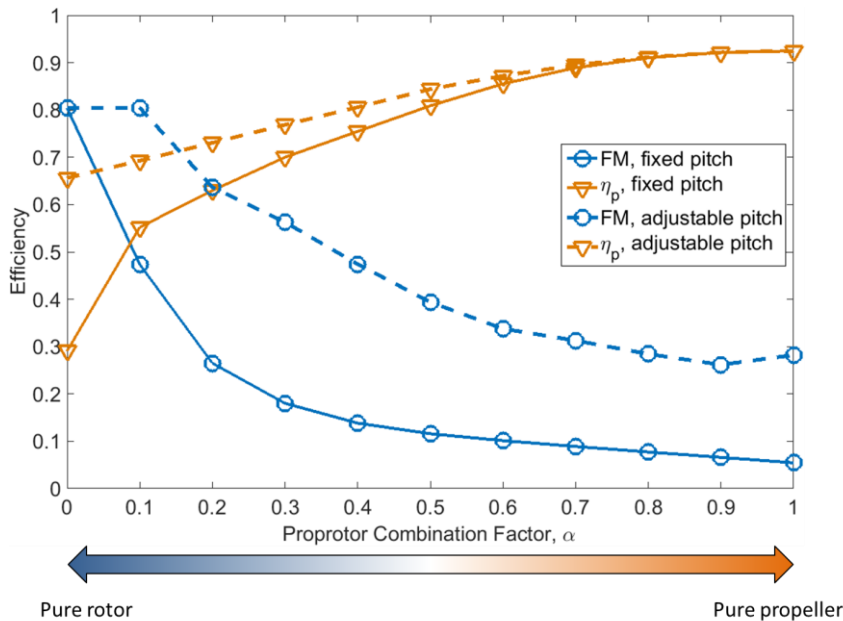

- Optimized rotor and propeller designs were combined to produce a proprotor with excellent performance in hover and forward flight
- Balance between FM and propeller efficiency based on needs from the system simulation
- Adjustable pitch rotor allows significant improvement over fixed pitch designs.

## Proprotor Characteristics

Radius	1.32 ft
# of blades	2
Taper ratio	0.25
Inboard twist	19.8°
Outboard twist	9°
Transition radius	0.87R
Airfoil	SD7032
Solidity	0.0745

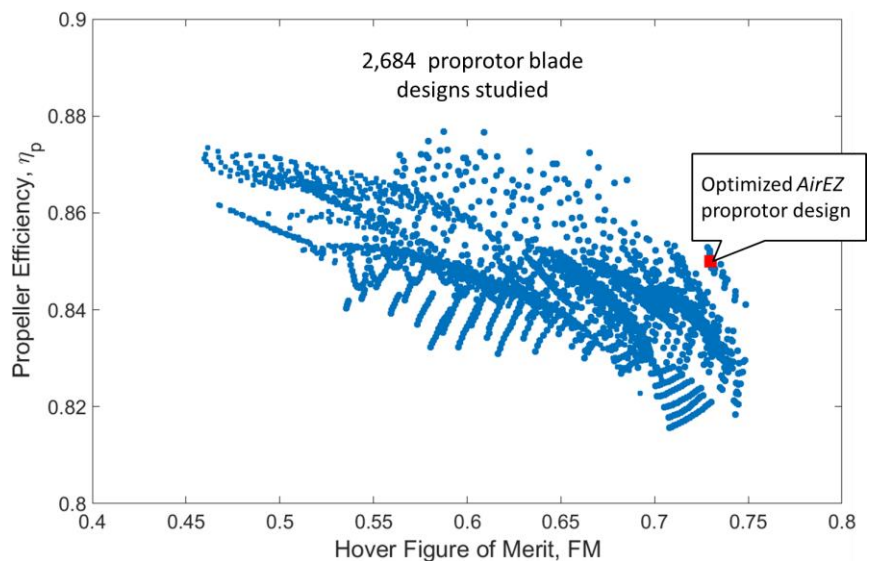

# PROPROTOR HUB AND SAFETY

The rigid proprotor hub was designed to allow the collective pitch variation necessary to hover efficiently and cruise at high speeds.

- Linear actuator used to push collective control rod
- Turnbuckles on pitch links allow tracking and balancing of rotors
- Simple pitching mechanism allows easy maintenance for the entire fleet
- Bearing material selected for unique loading of system

- **PTFE plain pitch bearings** for the low load and low rotation rate condition between blade grip and hub base
- **Bronze SAE 841 plain bearings** for the low pitch link load and high rotation rate condition between actuator rod and pitch link crossbar
- **Steel ball bearings** (thrust bearing) to take high centrifugal loads

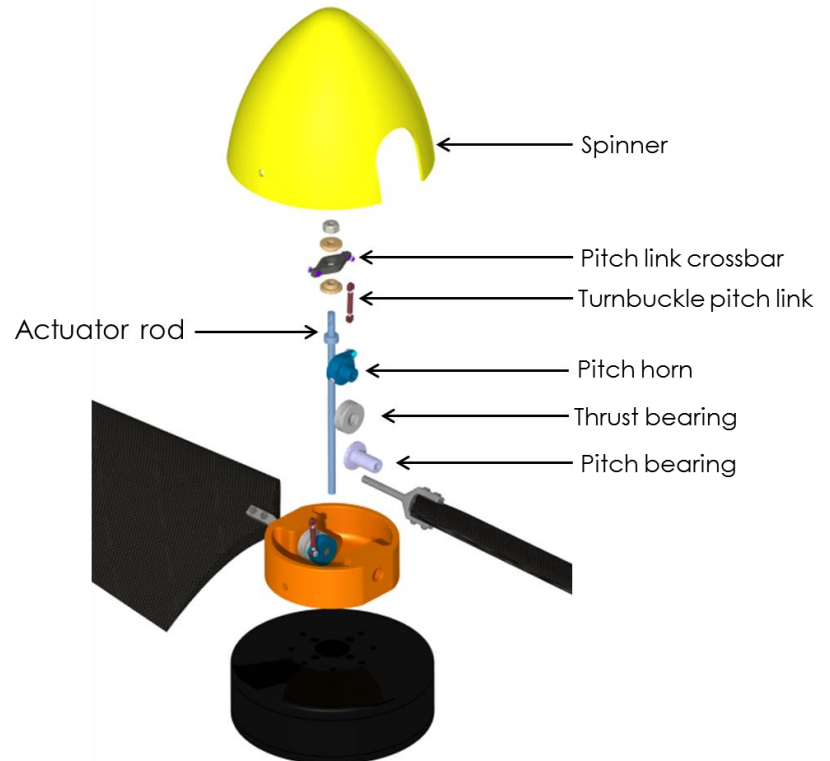

## Proprotor Operating Conditions

	Hover	Cruise
RPM	1750	750
Root pitch	33.36	70.34
Efficiency	FM = 0.73	$\eta_p = 0.85$

- Vehicle can safely land in one motor inoperative scenario using the proven quadrotor control system
- Emergency parachute allows vehicle to safely descend in case of multiple power plant failure

# EFFICIENT POWER PLANT

AirEZ is powered by lithium-sulfur batteries that have proven high energy density, while being lightweight, safe, inexpensive and environmentally friendly. Rapidly advancing battery technology enables easy improvements to the system in this future-proof design. As lighter and more powerful batteries become available, battery packs can be upgraded for higher payload and longer range.

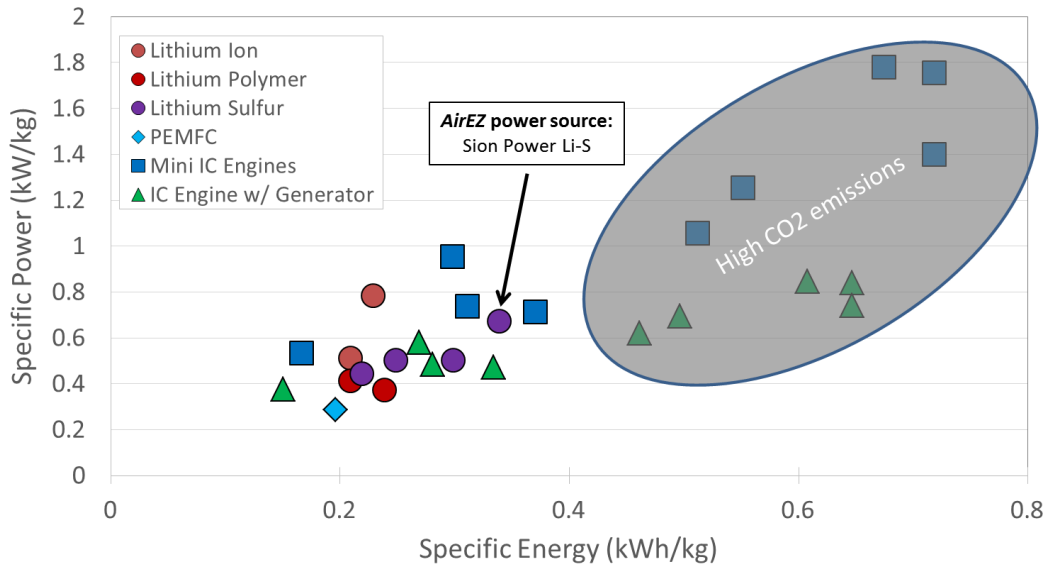

## 3 Year Estimated CO<sub>2</sub> Emissions and Costs

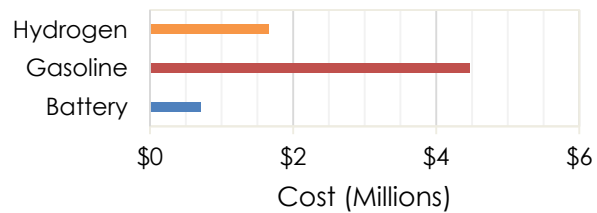
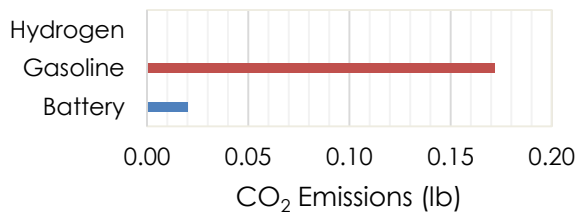

The modularity of batteries combined with the hinged battery compartment of the fuselage enable quick power pack changes between missions, minimizing downtime between deliveries and maximizing system productivity.

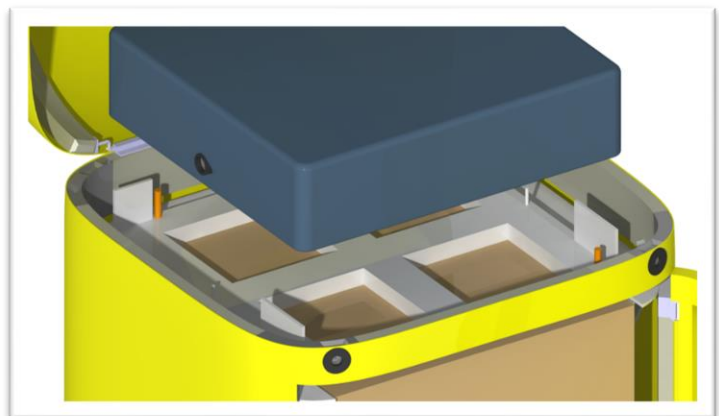

# OUTSTANDING VEHICLE PERFORMANCE

The *AirEZ* vehicle is able to achieve long-range high speed flight by combining the outstanding hover performance of a quadrotor and the high speed efficiency of a fixed-wing aircraft.

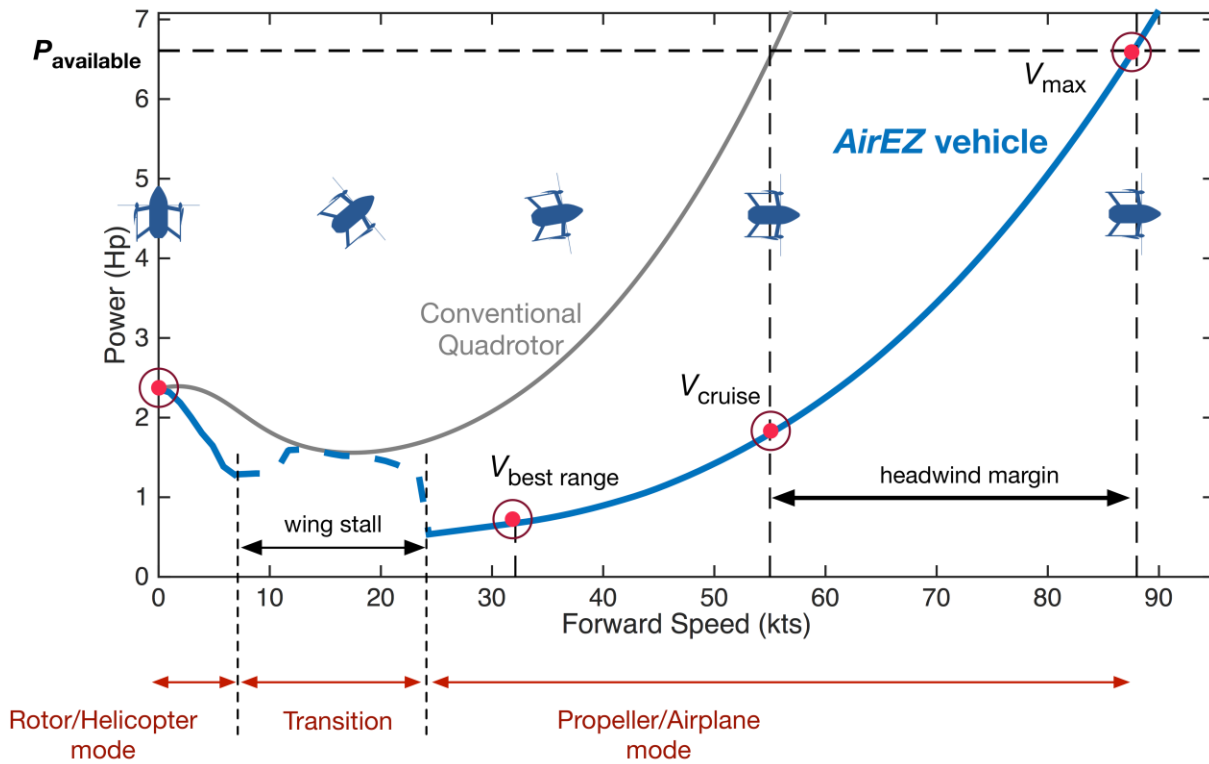

Vehicle Performance	
MGTOW	38.5 lbs
$V_{max}$	88 knots
Best Range at GTOW	175 miles
Max endurance	6 hours
$L/D$	4.7

The *AirEZ* vehicle is deployable in a variety of non-ideal environments, allowing the possibility of system implementation in any urban market across the U.S.

- High hover ceiling 7,900 ft
- Ability to operate in ISA +40°C conditions
- Operate in up to 40 knot winds

# LOW MAINTENANCE STRUCTURE

The RFP specifies an operating life of 300 days per year for three years. On each operating day, the system is active for 10 continuous hours. This leads to a design system life of 9000 hours, resulting 3.15 million cumulative flight hours for the entire fleet. Coupled with the suggested high cost of labor specified in the RFP (\$100/hr), special care was taken to ensure that vehicles can be repaired easily and quickly both in the field and offline.

- Aluminum 6061-T6 joints – easy use of standard fasteners and high corrosion resistance for all-weather flight (and treated to prevent galvanic corrosion)
- Carbon fiber composites – components consist of large single piece structures
- UHMW polyethylene package compartment – low cost, low weight, and low friction for easy sliding of package boxes
- Assembled with standard fasteners – very quick assembly and replacement of parts
- Airframe structure consists of 17 major parts for easy storage (8 struts, 4 landing gear stilts, 2 wings, and 3 fuselage sections). This leads to a lower spare parts inventory and easy replacement.

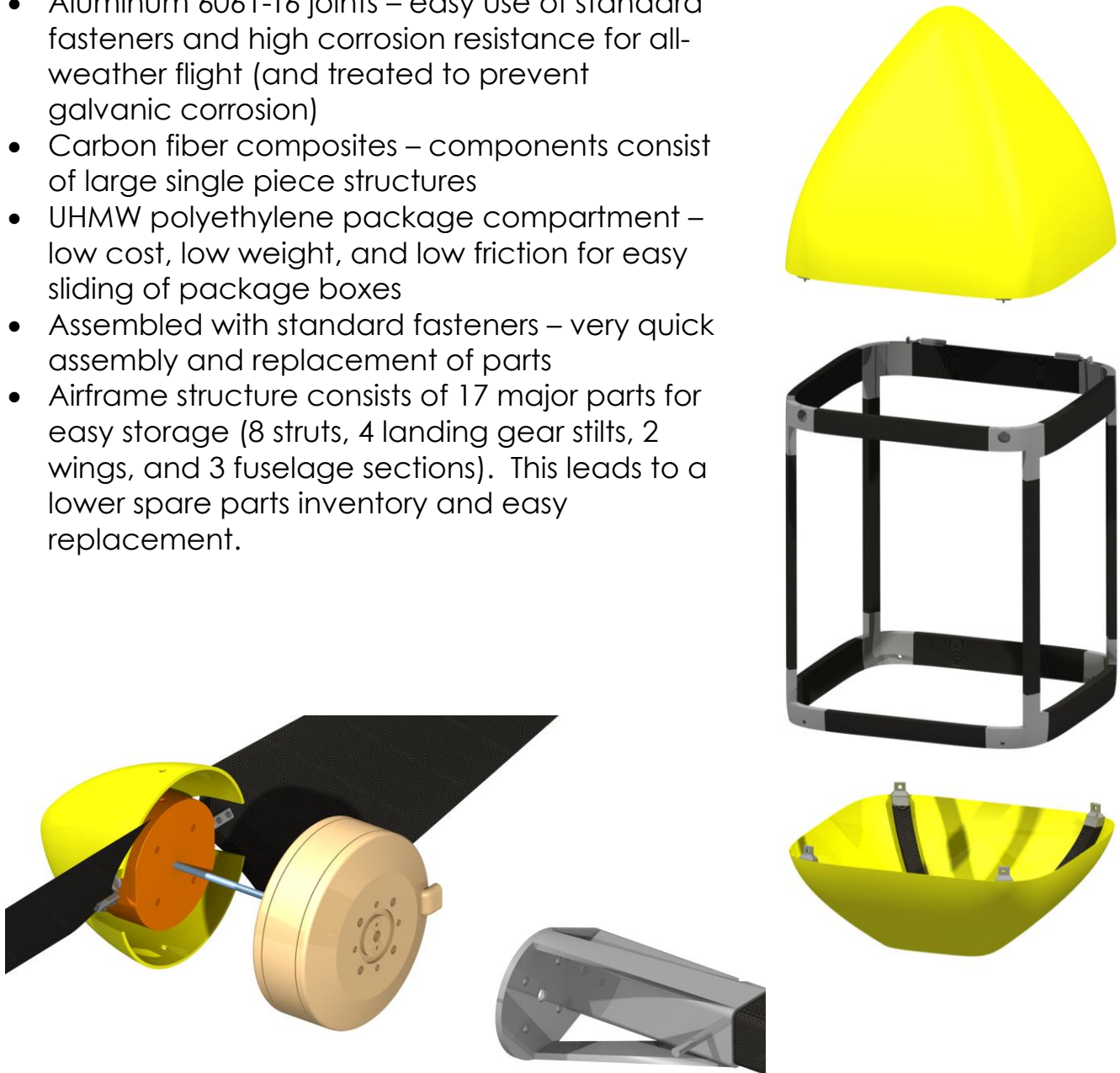

# AUTOMATIC PACKAGE LOADING/DELIVERY

A single *AirEZ* vehicle can deliver up to 4 packages per trip, a capability that results in higher mission success rate and lower system cost. A light-weight robust mechanism with minimal parts is capable of delivering multiple packages of different sizes upon landing. An advanced onboard sensor suite provides sense-and-avoid capabilities to avoid terrestrial obstacles.

*AirEZ* utilizes a simple screw conveyor mechanism to push packages through the automatic door. The mechanism also adjusts the lateral CG position after each package is delivered for optimum stability. Adequately sized servos and an interconnect shaft ensure that the mechanism is operable even if one servo fails.

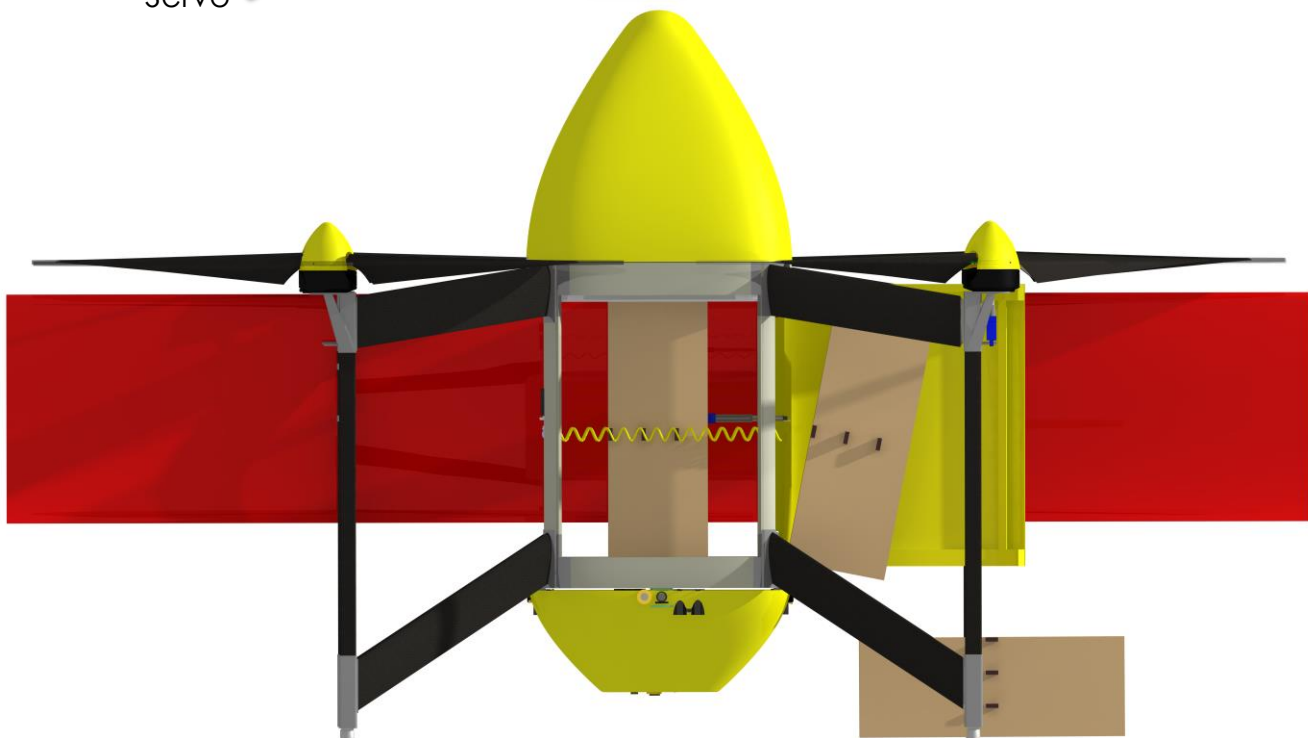
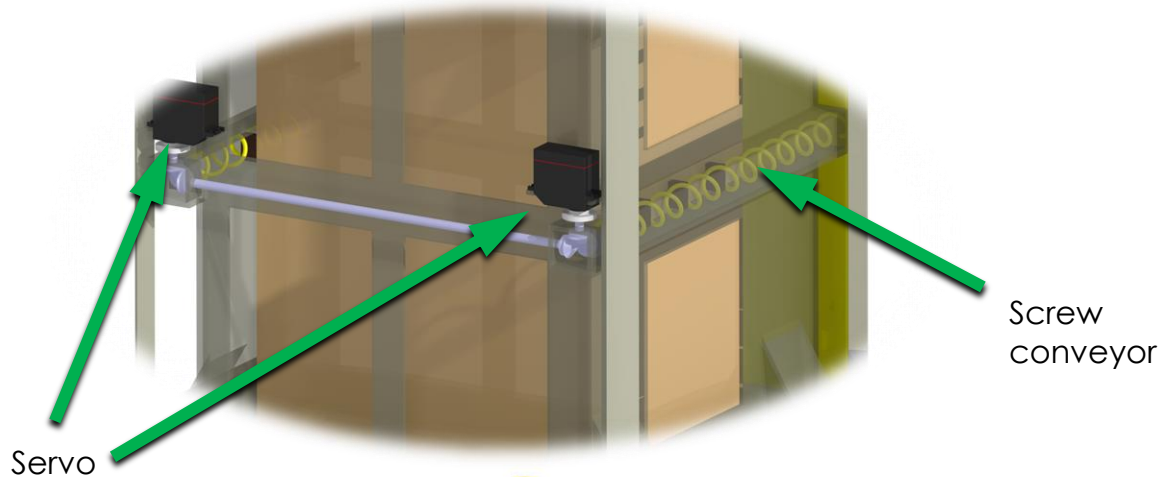

# CONTROL STRATEGY

- Vehicle control and stability is achieved using rotor differential RPM
- Airfoil on vehicle struts provides passive stabilization in forward flight
- Proven quadrotor control scheme can be used in both hover and cruise
- No other control surfaces required – minimal complexity & light-weight design

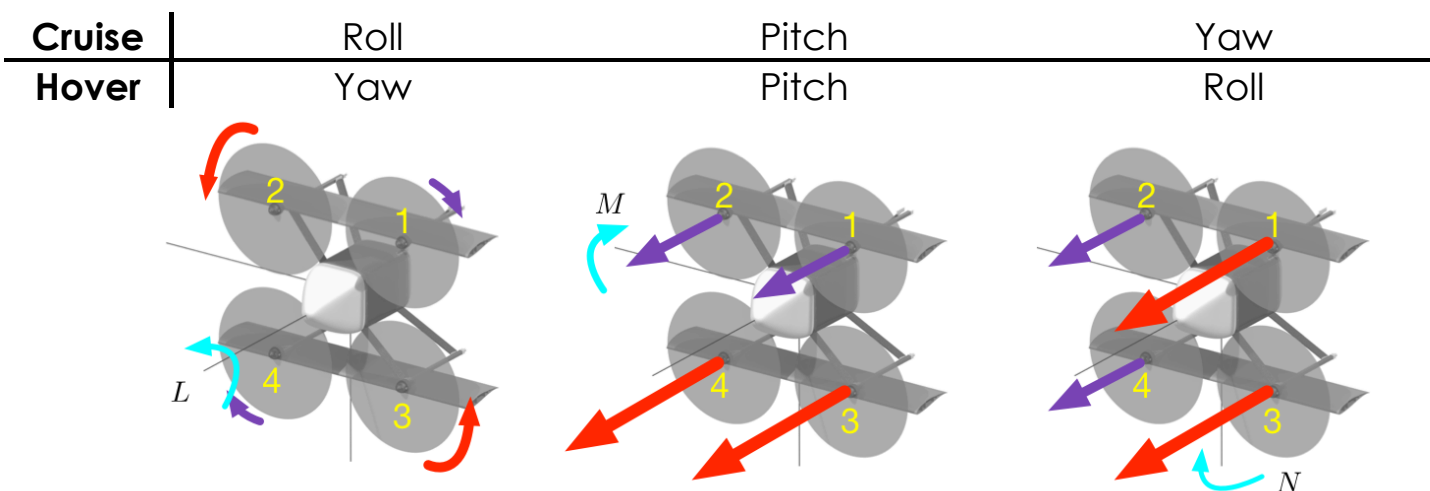

AirEZ implements a gust attenuation and stability augmentation procedure inspired by the mechanosensory systems of flying insects through use of acceleration sensors distributed across the airframe.

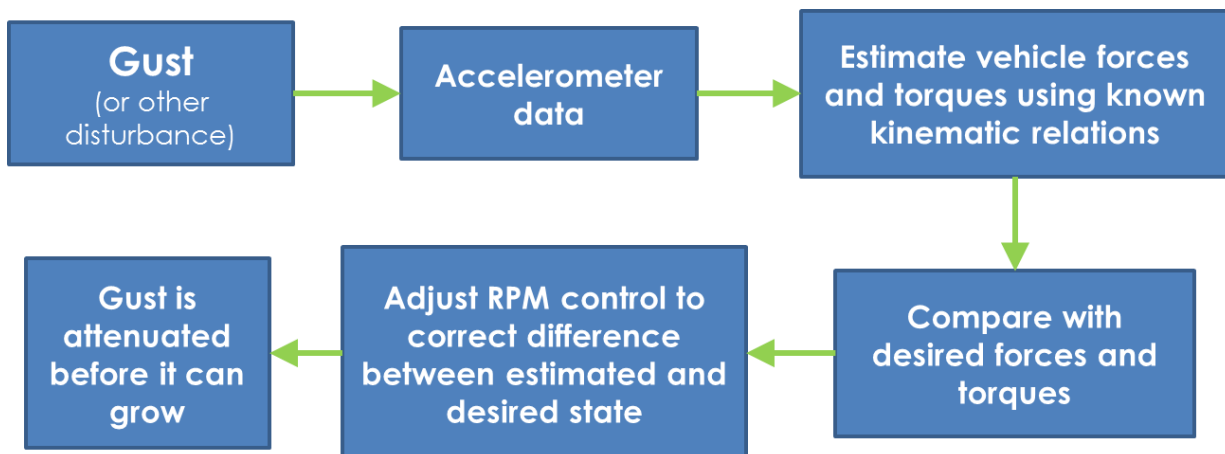

# TRANSITION

For a tailsitter vehicle, the transition from hover to cruise and vice versa is critical. The transition needs to be quick, efficient, safe, and reliable. The AirEZ transition maneuver has been optimized to be highly efficient and was successfully demonstrated on a scaled vehicle.

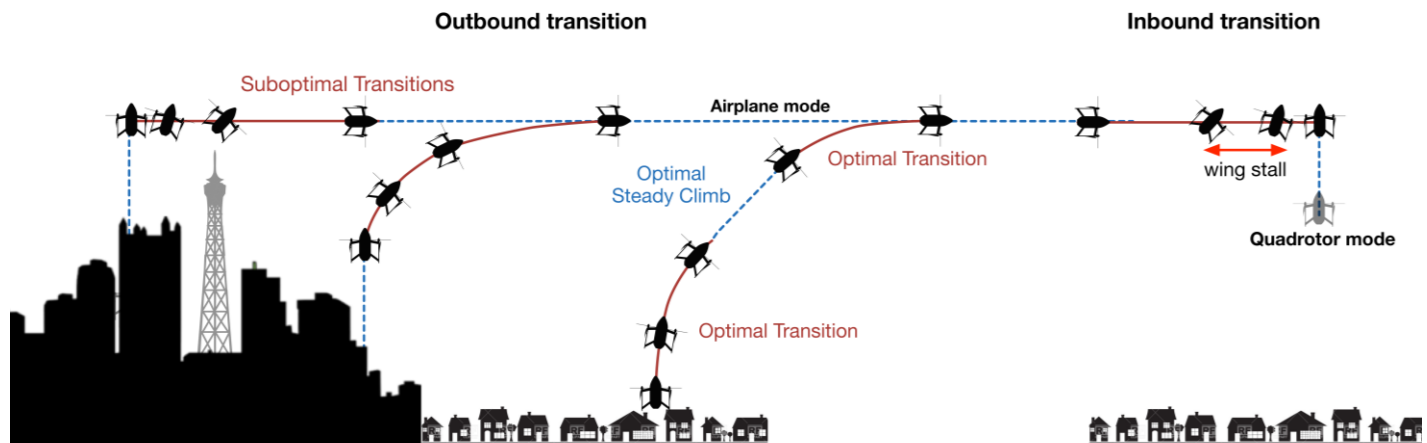

## Outbound

- Optimal transition maneuver executed autonomously based on allowed vertical displacement within FAA guidelines and skyline profile
- Trim analysis used to select efficient flight profile
- Avoids wing stall by transitioning in nearly axial flight
- Transition uses 6.6 hp to move rapidly to stable forward flight, using only 0.8% of the battery capacity for entire maneuver

## Inbound

- Avoids the altitude gain typical of tailsitter vehicles by using drag from the fuselage, wings and rotors to decelerate
- No additional power required - ensures excess vehicle power can be used for attitude control and stabilization during wing-stall
- Transition uses 3.4 hp and only 0.3% of battery capacity

Root pitch is changed during transition at 23 knots to minimize power. Each transition maneuver is completed within 20 seconds. Simulations with full non-linear vehicle dynamics and experiments with subscale vehicles validates transition procedure.



# Overview: Avionics Suite

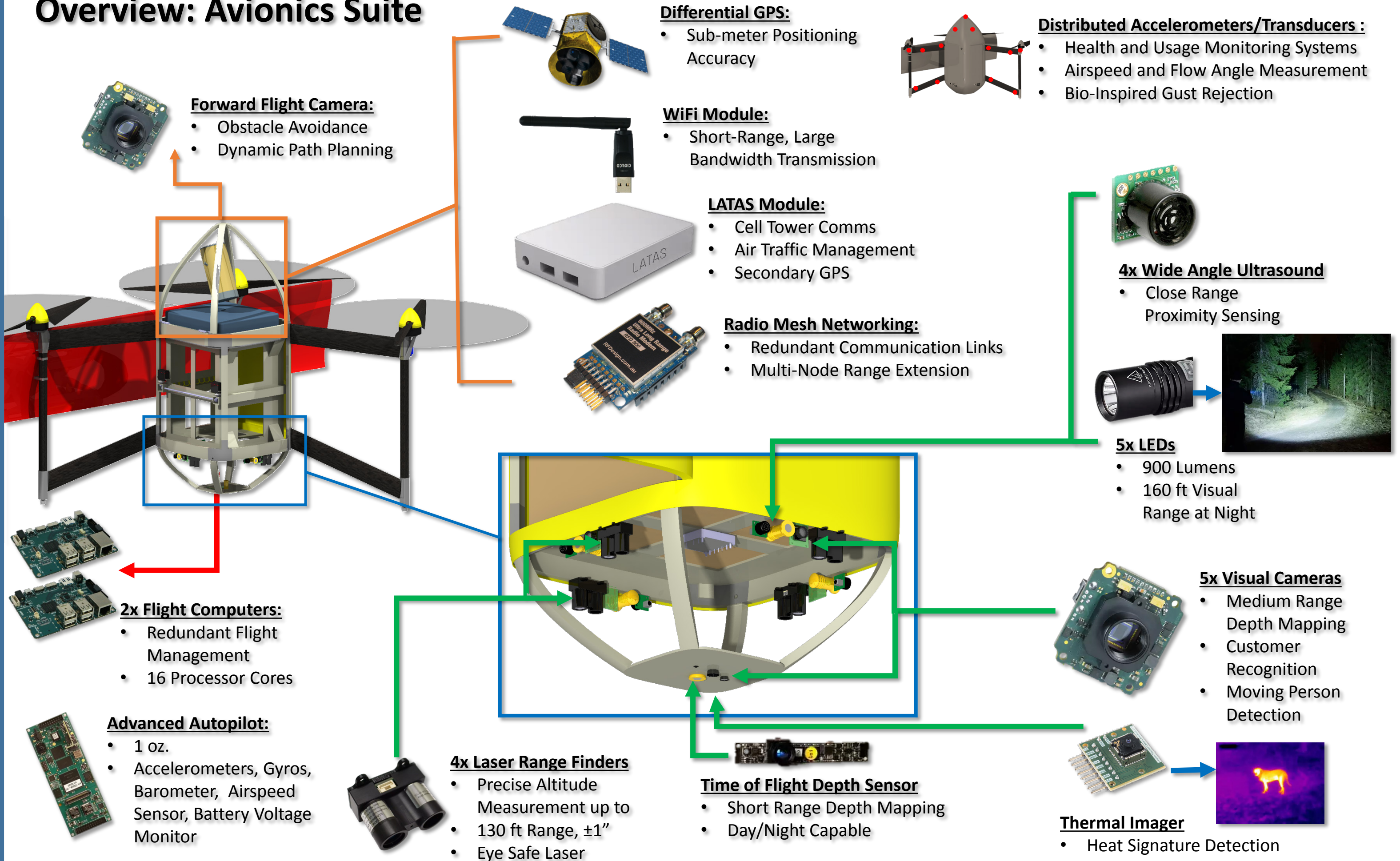

# DEMONSTRATED VEHICLE CONCEPT

## The AirEZ Micro:

A scaled vehicle demonstrating feasibility of the full scale design



Utilizes the in-house designed ELKA-R Board

- Microprocessor: Cortex-M4
- IMU: MPU-9150
- 2.4 GHz wireless transceiver
- Loop rate: 1000 Hz
- Mass: 1.7 g
- Thickness: 1 mm

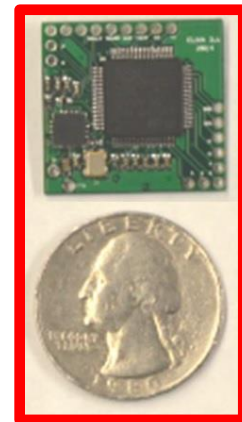

# SUMMARY

The AirEZ delivery system has been designed in response to the RFP for an aerial system of systems capable of delivering packages to customers in an urban environment. The University of Maryland AirEZ design utilizes an existing warehouse as a distribution center for a unique delivery concept that is scalable, robust, and cost-efficient.

The AirEZ UAV's unique quadrotor-biplane-tailsitter configuration fuses the engineering advantages of each of the three concepts:

- 1) **Quadrotor** – Efficient hover and superior stability
- 2) **Biplane** – Efficient high speed cruise in a small footprint
- 3) **Tailsitter** – A mechanically simple design with minimum parts

The ability to carry multiple packages per trip enables a high level of mission success. Additionally, the AirEZ vehicle is stable in gusts and can complete its mission even with a 40 knot headwind.

The innovative use of proven technologies ensures complete operational safety, while a robust and redundant sensor suite enables safe, autonomous flight and delivery in unpredictable urban environments. The capabilities of the AirEZ system represent a paradigm shift in the logistics services market.

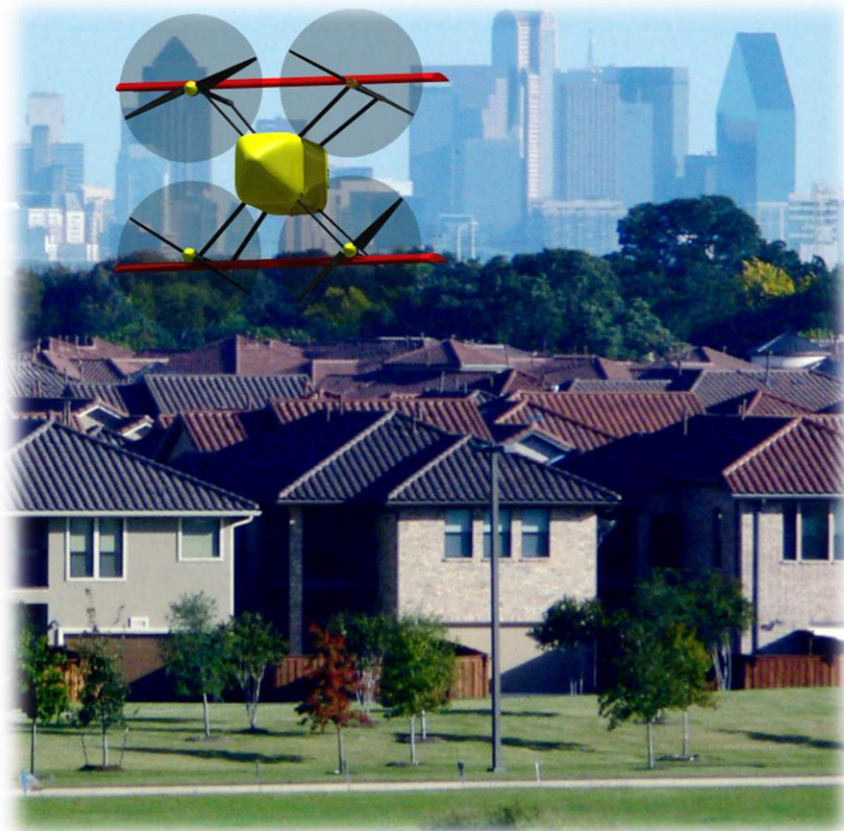

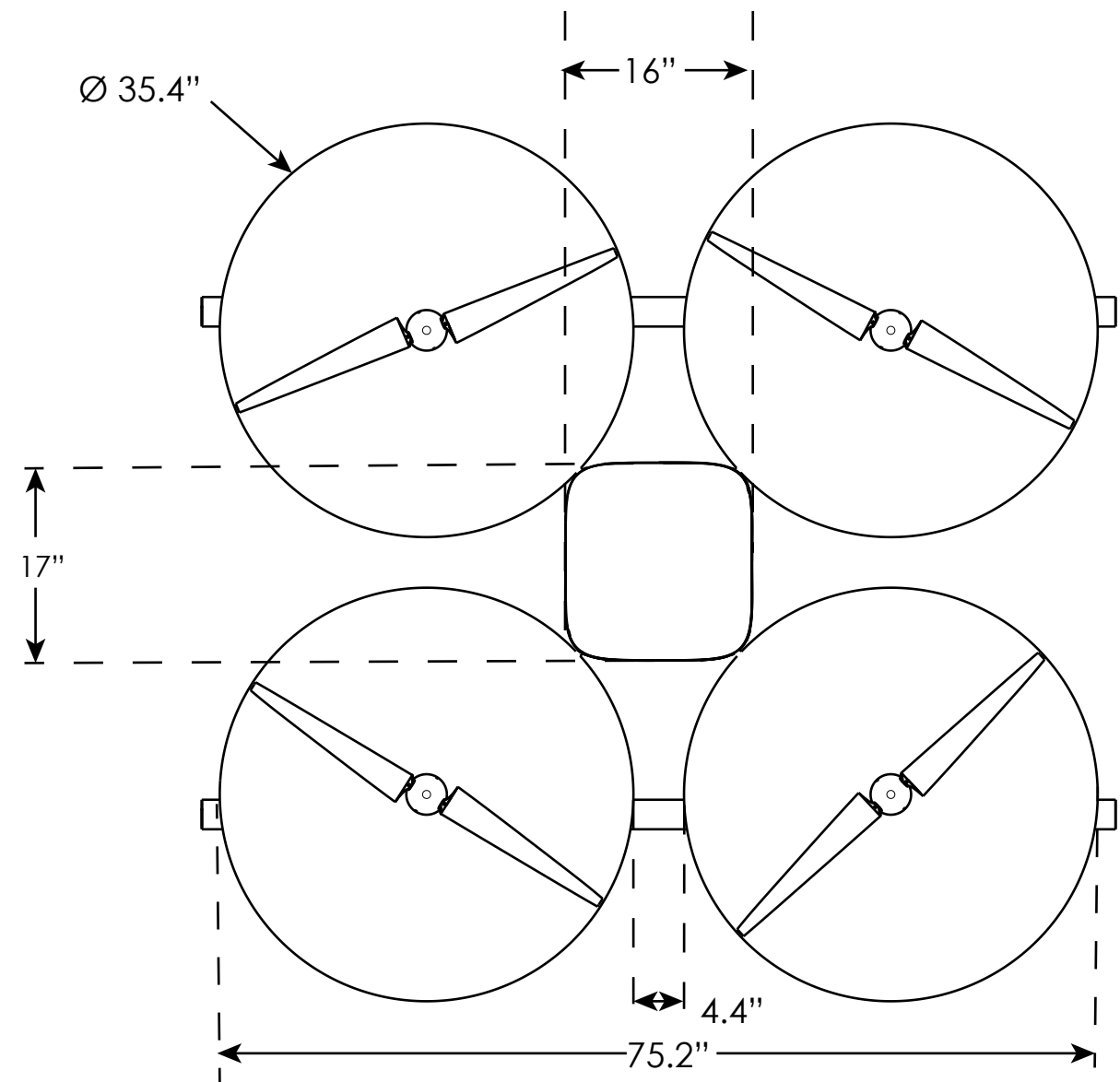
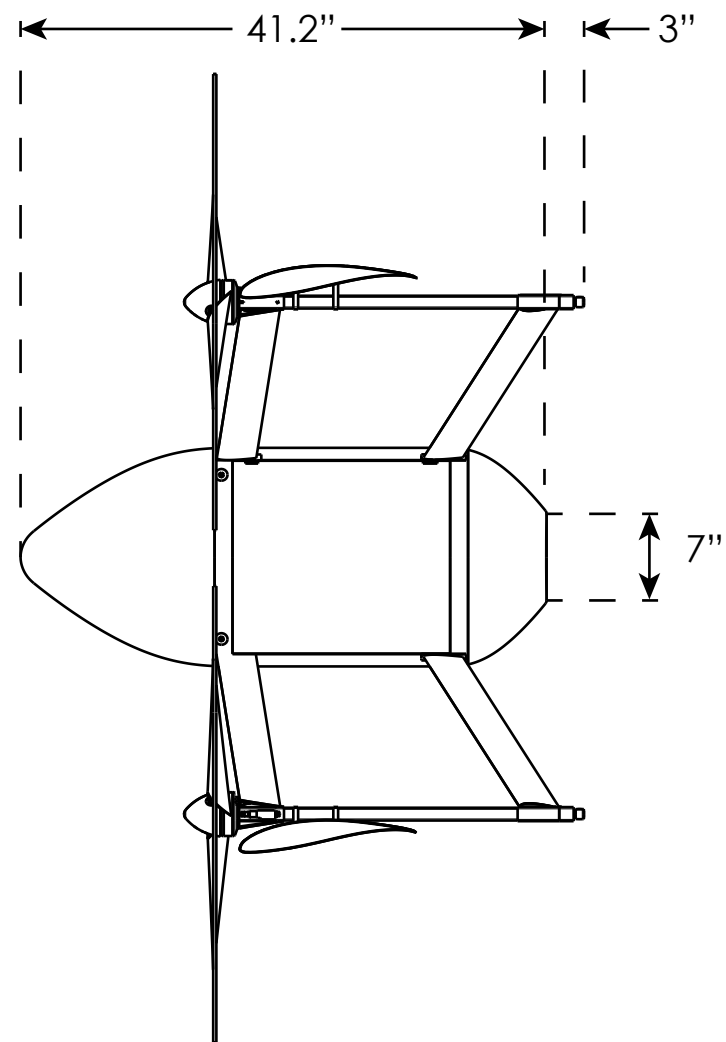
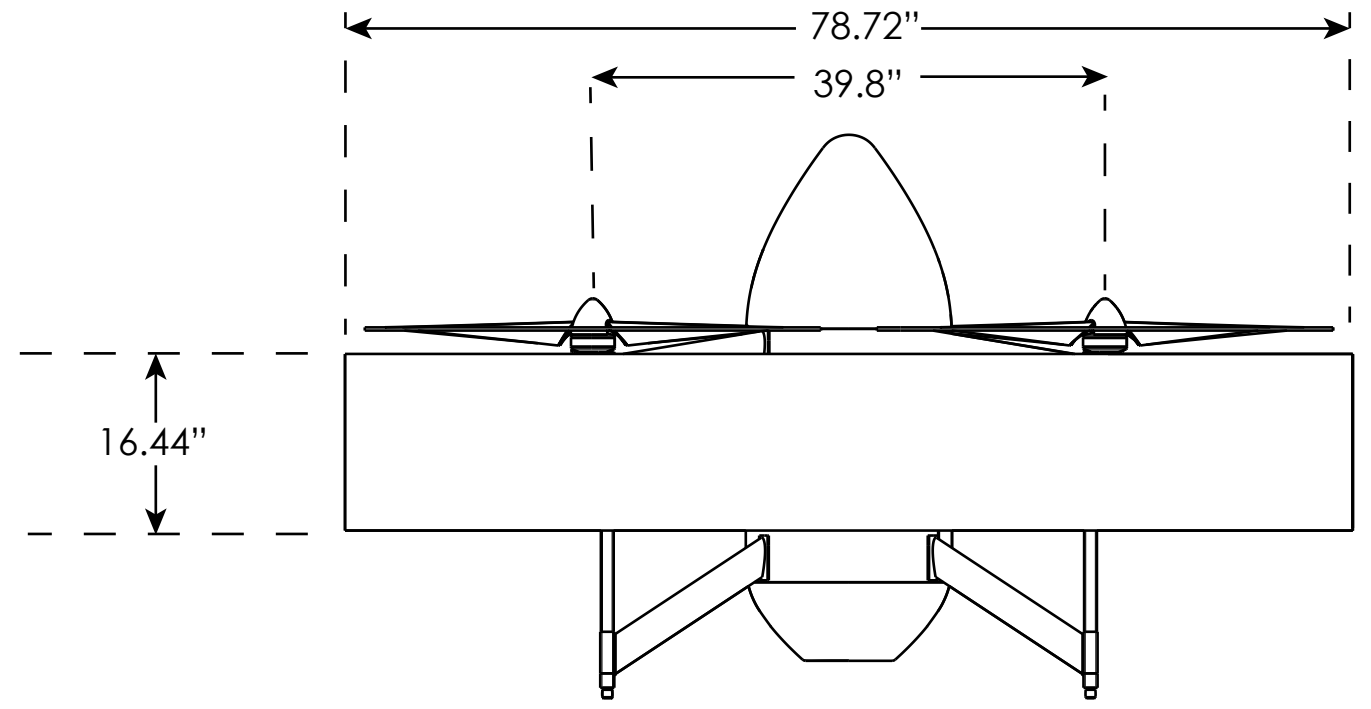
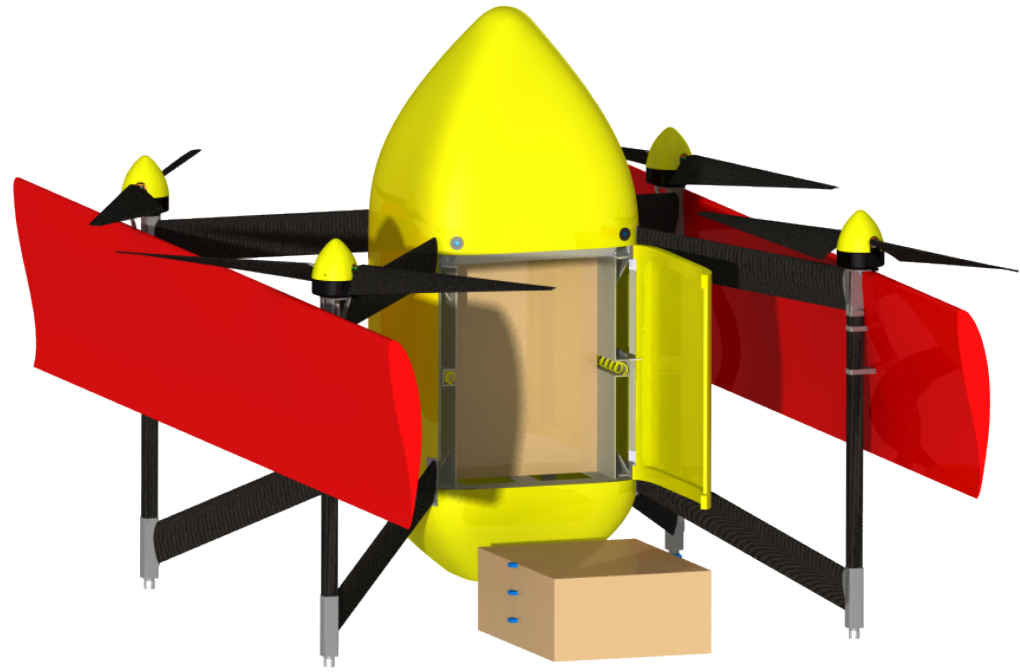

1:15 Scale